

Solar Pond

Iraq as a Case Study

Assist. Prof.

Anees A. Khadom

Department of Chemical Engineering

College of Engineering – Diyala University



Water is important to life. Man has been dependent on rivers, lakes, and underground water for his requirements. About 97% of the earth water is salty and only 3% of earth water is potable. Due to increase in population and rapid industrial growth, the consumption of fresh water is increasing day by day.

Desalination is the best solution for the above said problem. In existing desalination method, for mass production, fossil fuels are used. But availability of fossil fuels in the world is very limited.

Introduction

- A solar pond is simply a pool of saltwater which collects and stores solar thermal energy.
- One of the most interesting ways to generate solar thermal energy is through the use of a solar pond. A solar pond is a pond full of saltwater that is used for capturing and storing solar heat.
- Solar energy is an abundant and renewable energy source.
- A solar pond can be used for various applications, such as process heating, desalination, refrigeration, drying and solar power generation.

... Introduction

- ▶ Iraq has excellent solararity, ranging from 1800 to 2390 kw/m²/yr.
- ▶ This solar energy can be used as a new technology of solar pond and its application to desalination of reverse osmosis rejects in south of Iraq.



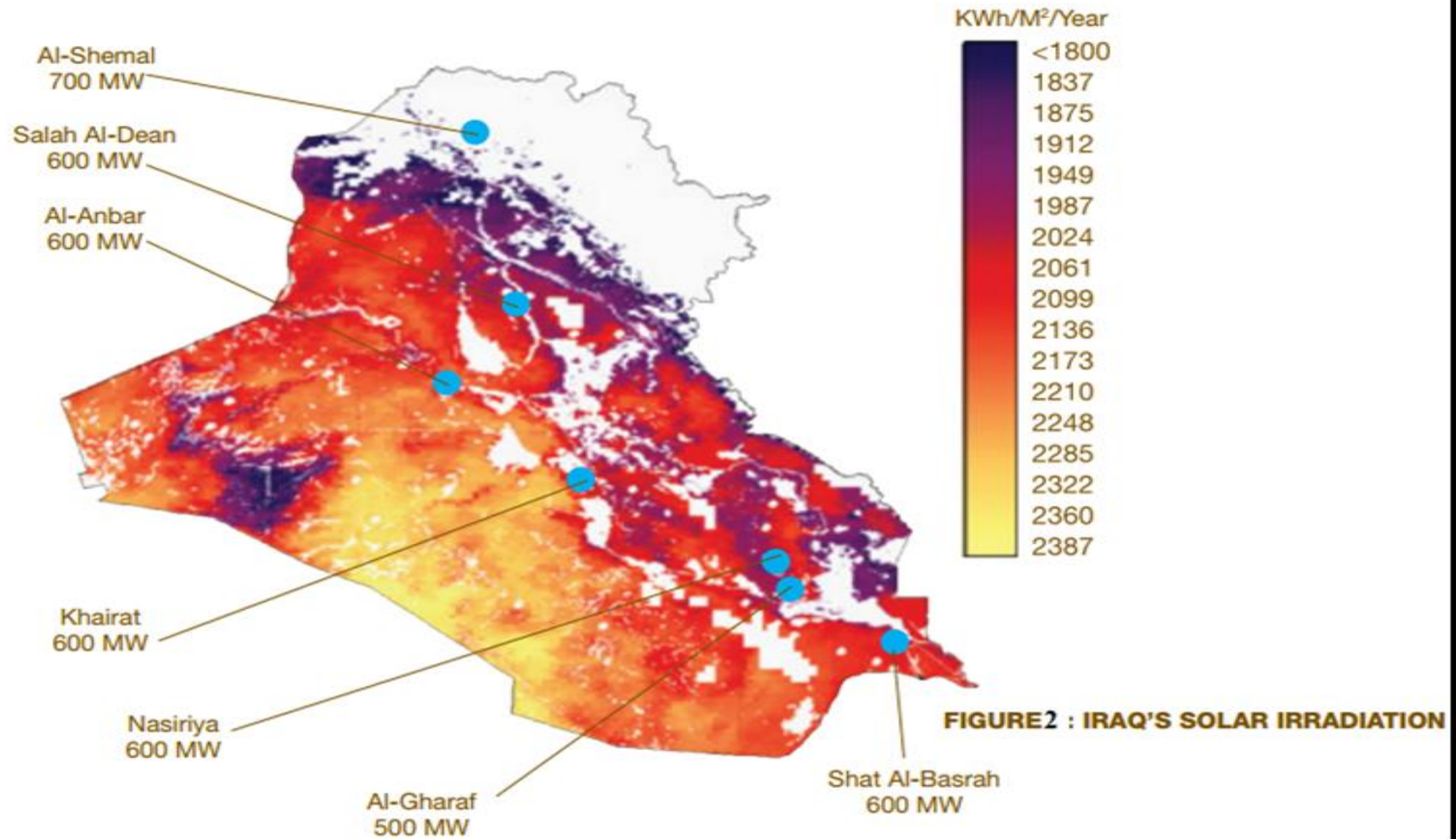

... Introduction

- ▶ **In a clear natural pond about 30% solar radiations reaches a depth of 2 meters.**
- ▶ **This solar radiation is absorbed at the bottom of the pond.**
- ▶ **The hotter water at the bottom becomes lighter and hence rises to the surface. Here it loses heat to the ambient air and, hence, a natural pond does not attain temperatures much above the ambient.**
- ▶ **If some mechanism can be devised to prevent the mixing between the upper and lower layers of a pond, then the temperatures of the lower layers will be higher than of the upper layers.**

General Energy Balance for Solar Pond

$$Q_{\text{net}} = Q_{\text{accumulation}} = Q_{\text{in}} - Q_{\text{out}}$$

$$Q_{\text{in}} = Q_{\text{solar}} + Q_{\text{bottom}}$$

$$Q_{\text{out}} \text{ (heat loss)} = Q_{\text{wall}} + Q_{\text{to surrounding}}$$

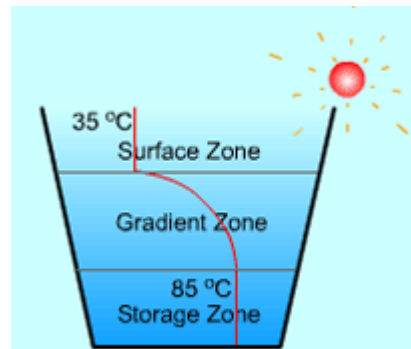
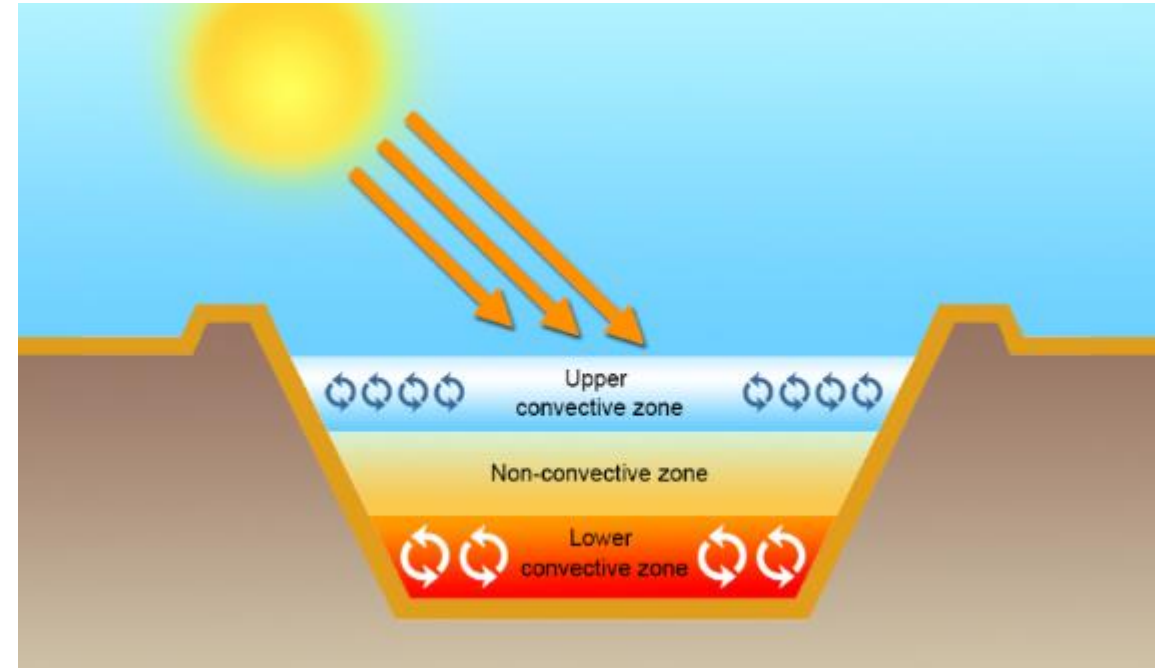

PROBLEM STATEMENT

The rejection solution (reject streams) normally out from reverse osmosis (R.O) units, membrane (R.O) unite have high solute concentration than that in R.O feed water. This concentration increasing could be reached up to 50%.The rejection solution mainly in all desalination projects using reverse osmosis membranes technology are disposed to the project raw water stream which may affect the on water sources in term of increasing the salinity and influence on Marian life.

Aim of the work

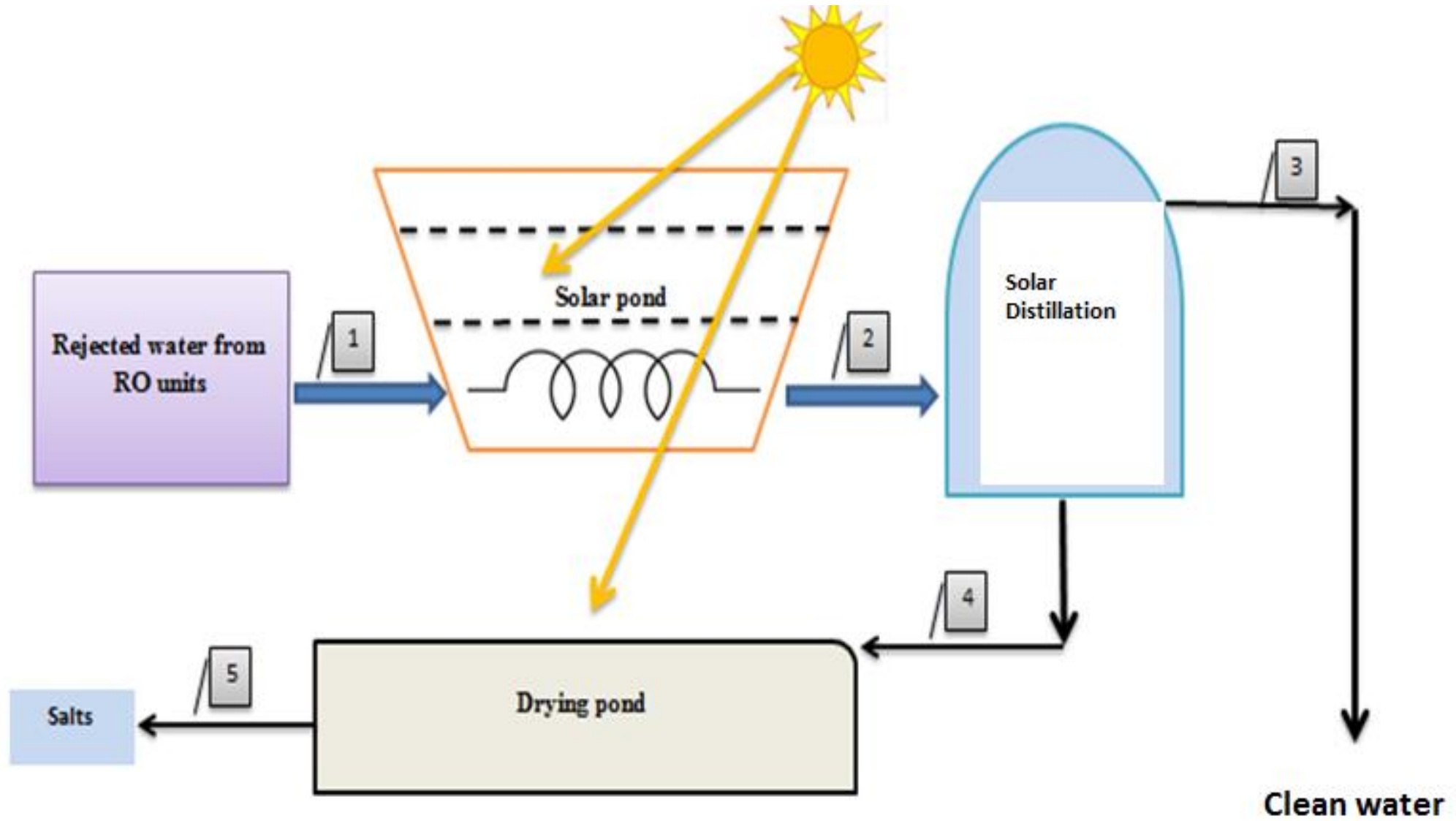

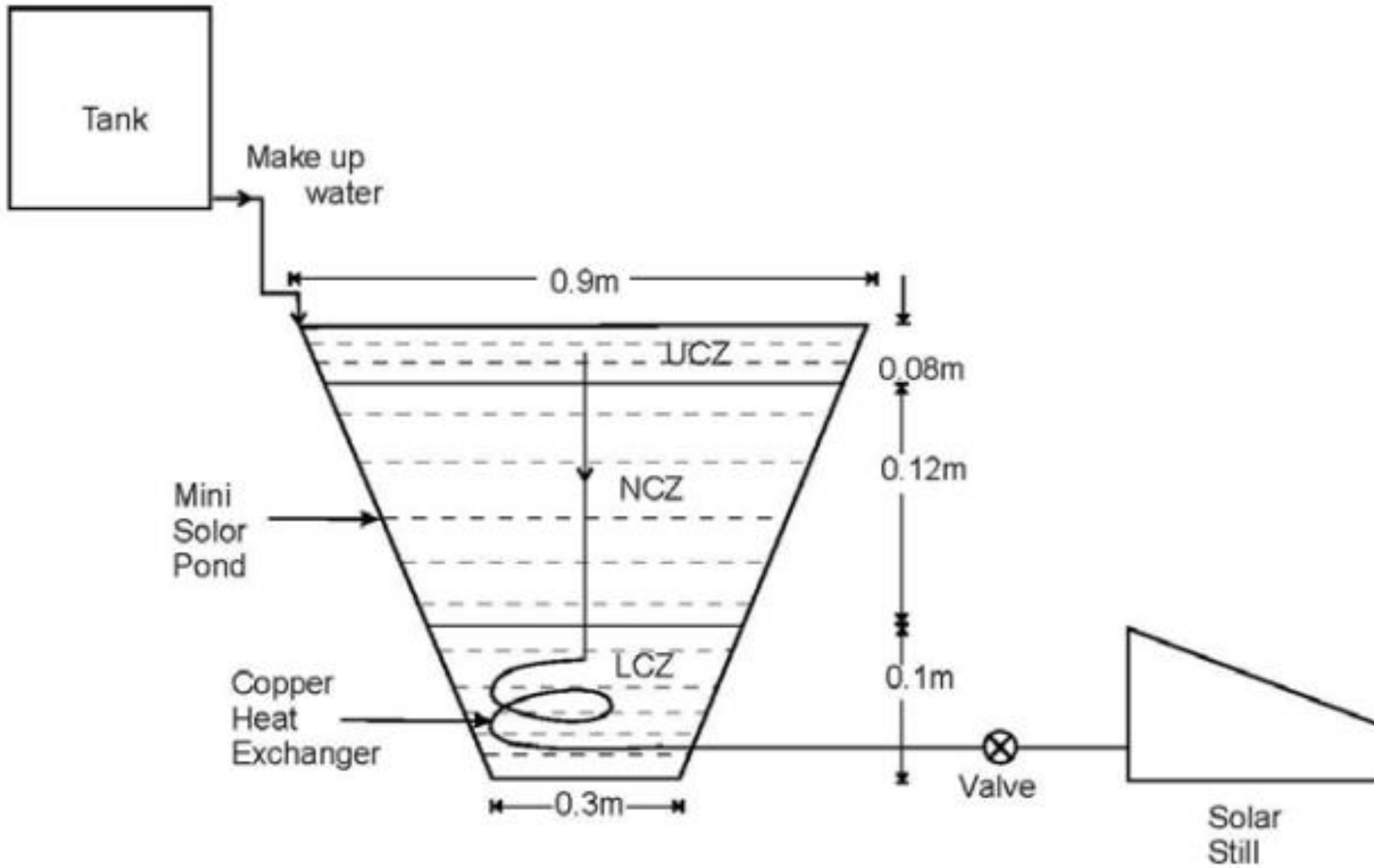

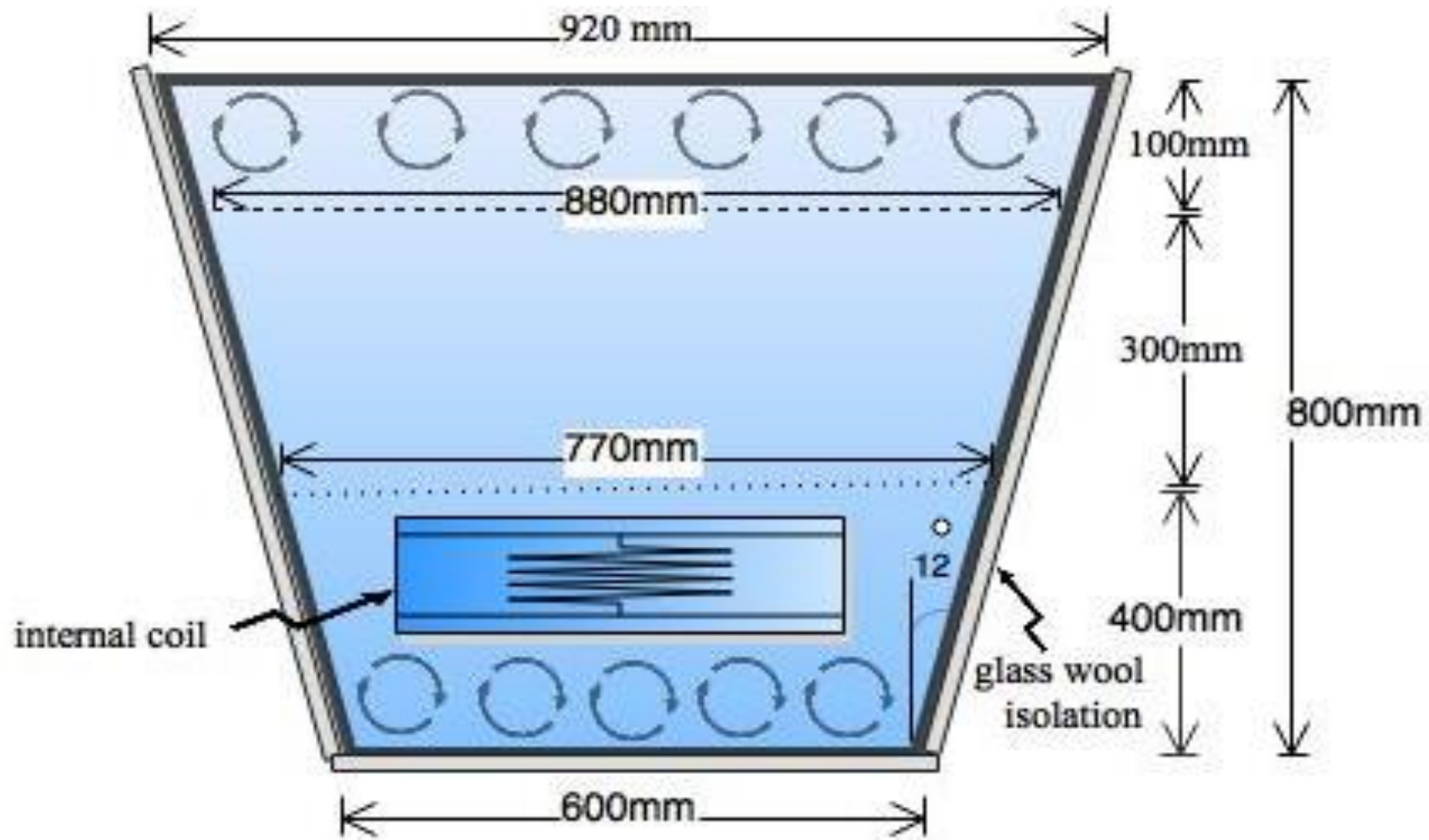



Solar still fabrication

Dimensions :

Breadth(width) =102 cm

Length = 69 cm

Height (front) =22 cm

Height (back) = 42 cm

Angle (θ) = 31°



Epoxy lining for solar still
Three layers epoxy coated
Food grade type



Glass sheet fixed at solar still
With thermocouples to indicate
temperatures



Solar pond (Trapezoidal shape) manufacturing
Base dimensions = 60×60 cm
Top surface dimensions = 92×92 cm
Height = 86 cm
obliqueness angle (θ) = 12°



Internal coil exchanger fixed inside solar pond at lower layer (heat store layer)
Diameter = 3/8 inch
Length = 10 m



Coal tar Epoxy lining and double layers of Isolation glass wool (5 cm thick)



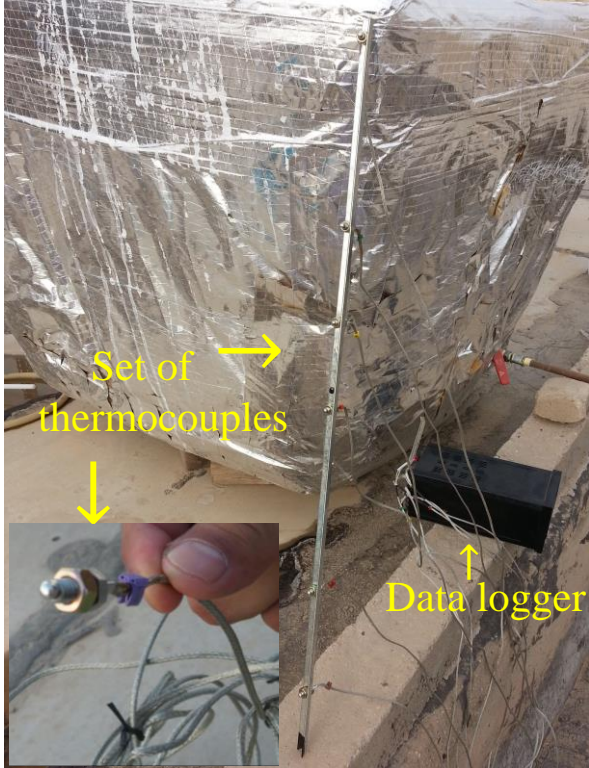

Set of thermocouples →

↑ Data logger



Data logger



Temperature/PH/TDS/EC meter

Solar power meter



Coil

Set of thermocouples group fixed
Solar pond inside and connected to
Data logger

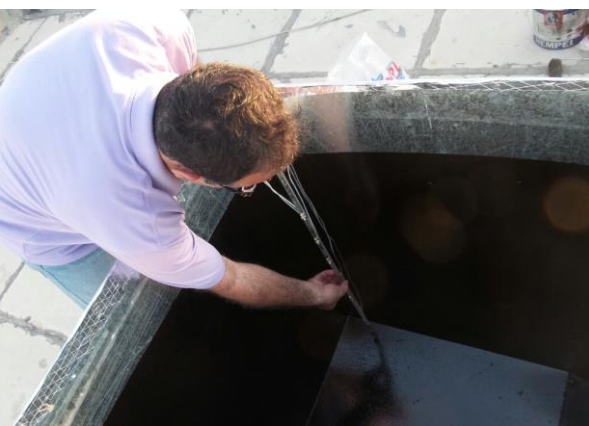

plastic perforated pipe (diameter = 20mm)
To fill solar pond

Hydrometer-Areometer →

Preparing the solution
Of lower layer

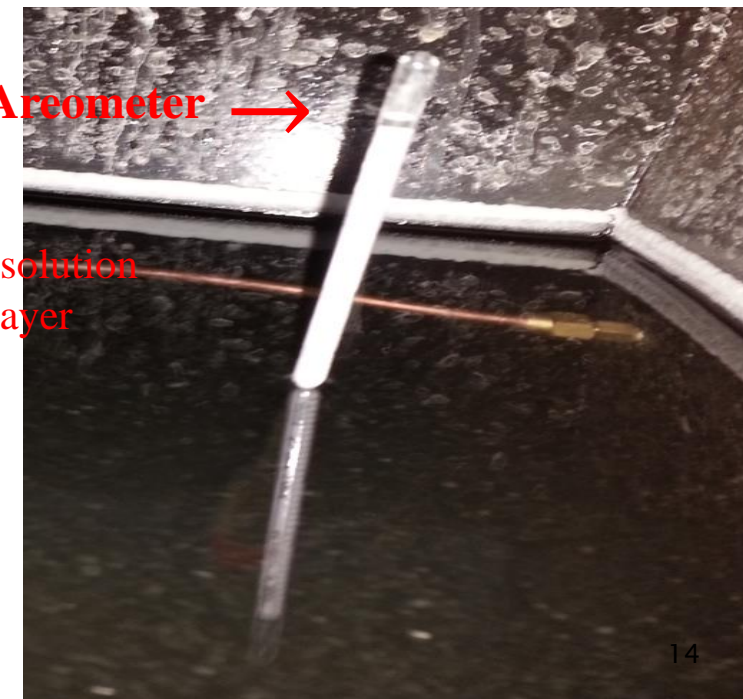

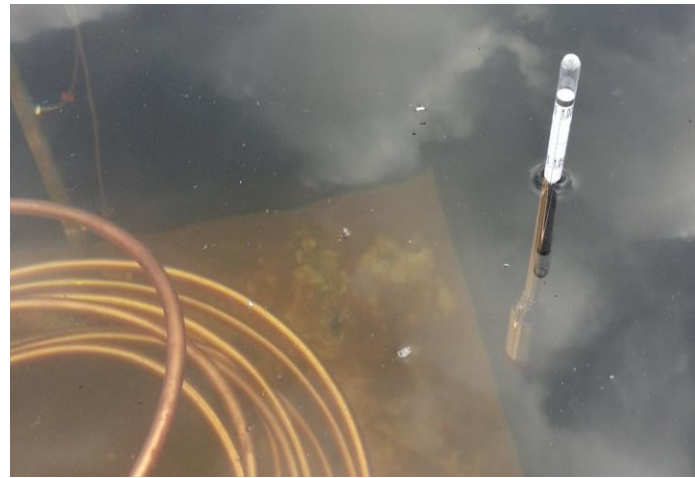

Different concentration for the intermediate (gradient) layer

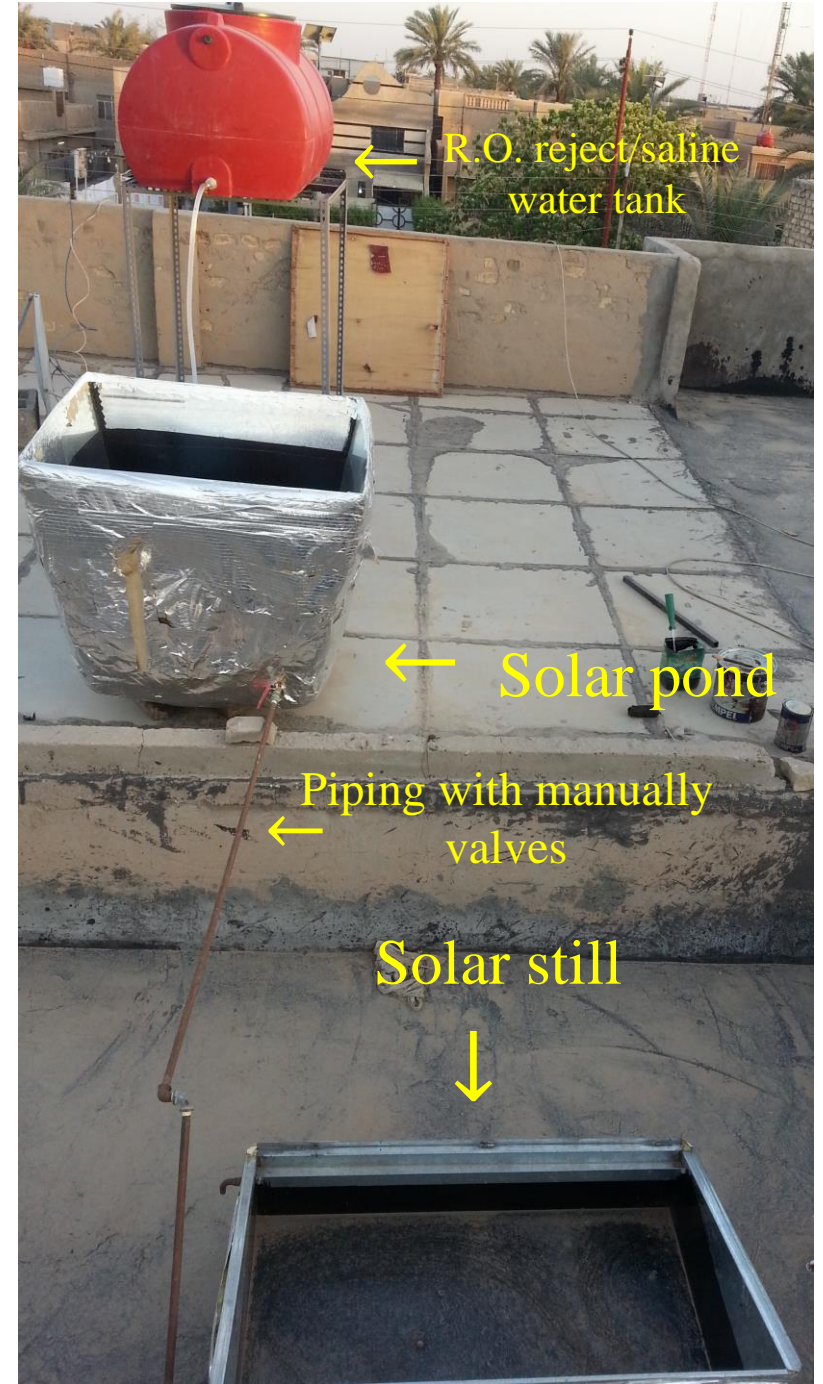
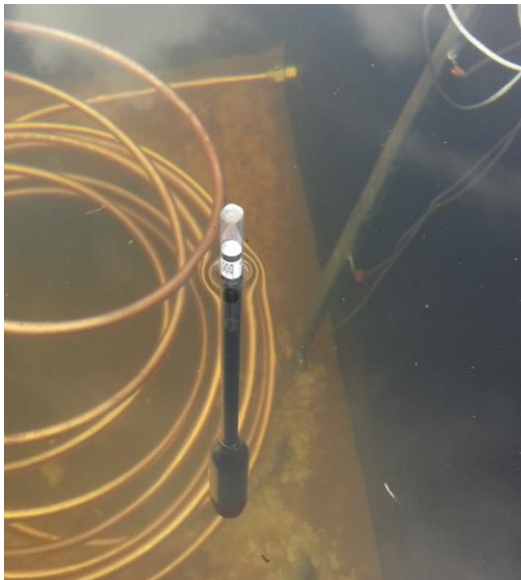

R.O. reject/saline water tank

Solar pond

Piping with manually valves

Solar still

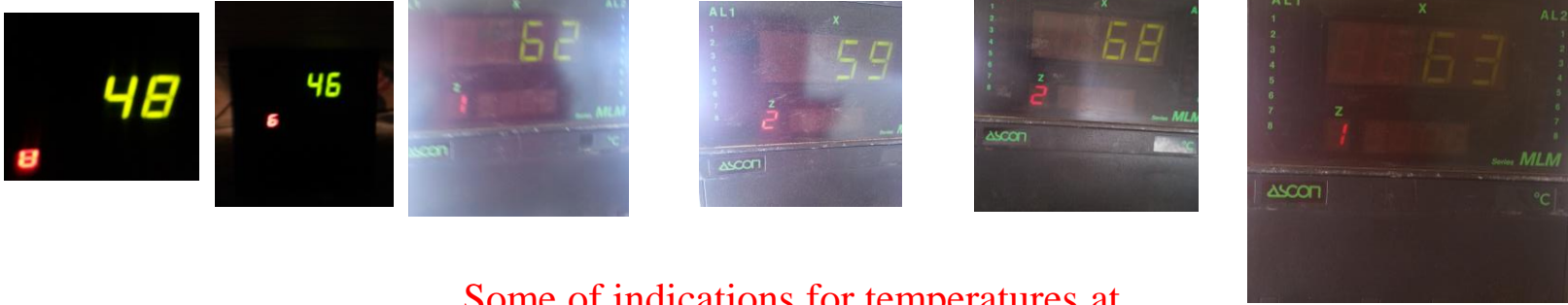

Some of indications for temperatures at lower layer which stability at 63 ,64 °C

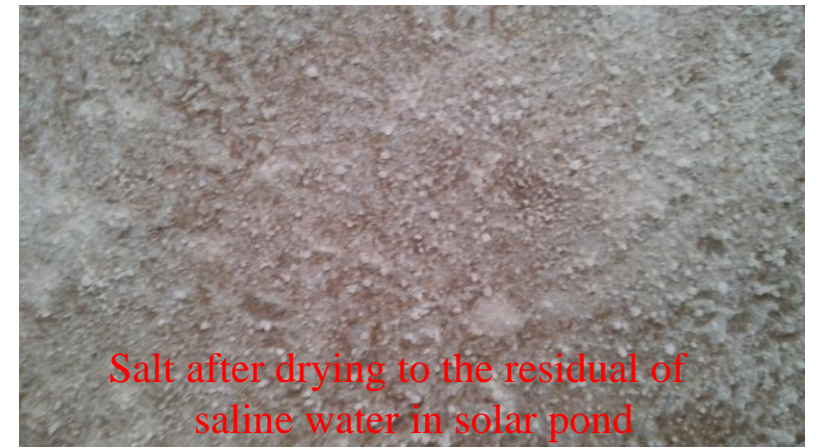

Salt after drying to the residual of saline water in solar pond



Effect of sunshade on productivity of water



Confirm of plastic cover above solar pond
To reduce make up water at upper layer
Due to evaporation



Many times in different days of condensation process
at solar still glass



Distilled water
TDS = 110 ppm

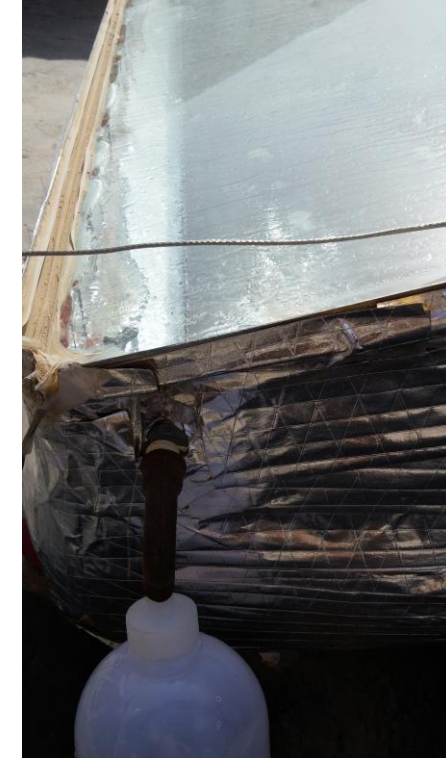

Water collection jar
Measuring bottle¹⁷

Results – Solar Pond

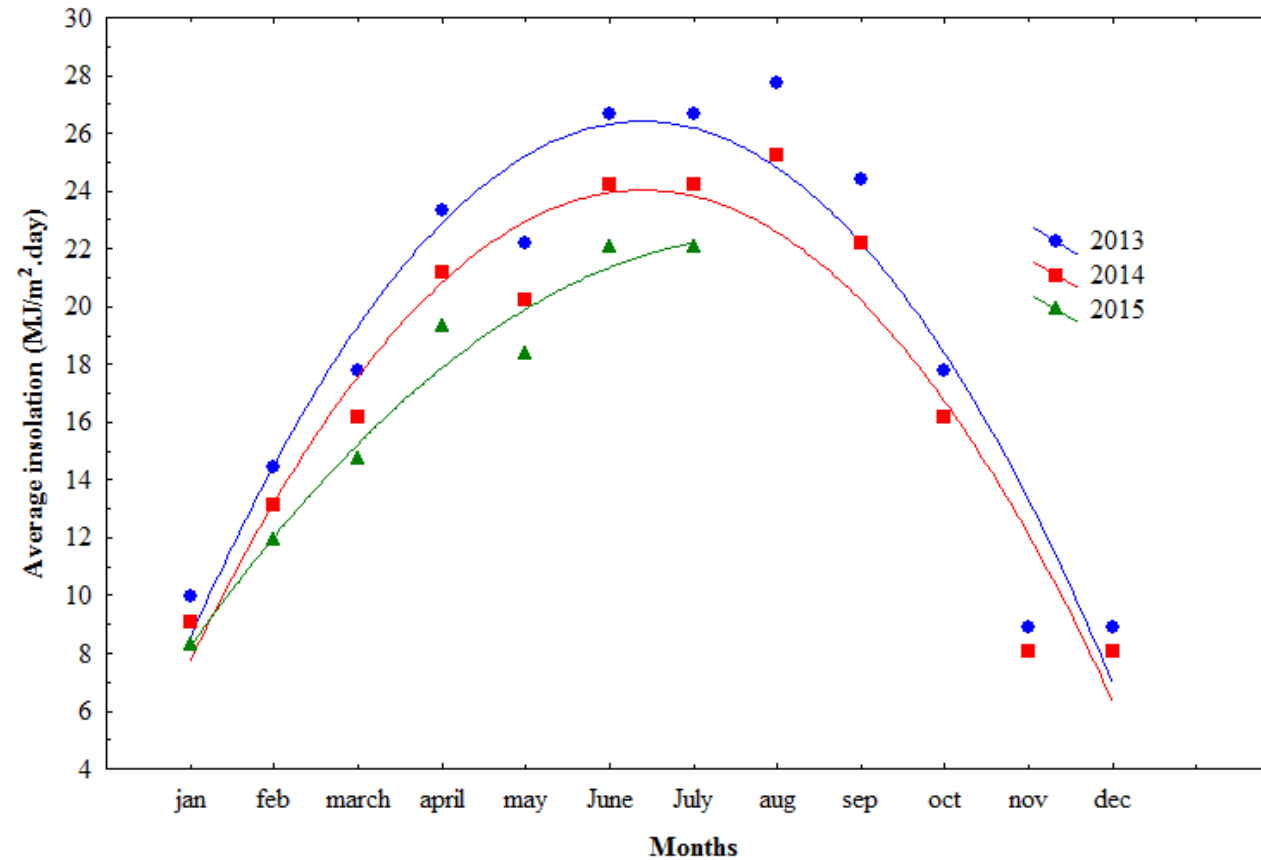

Average insolation in Baghdad

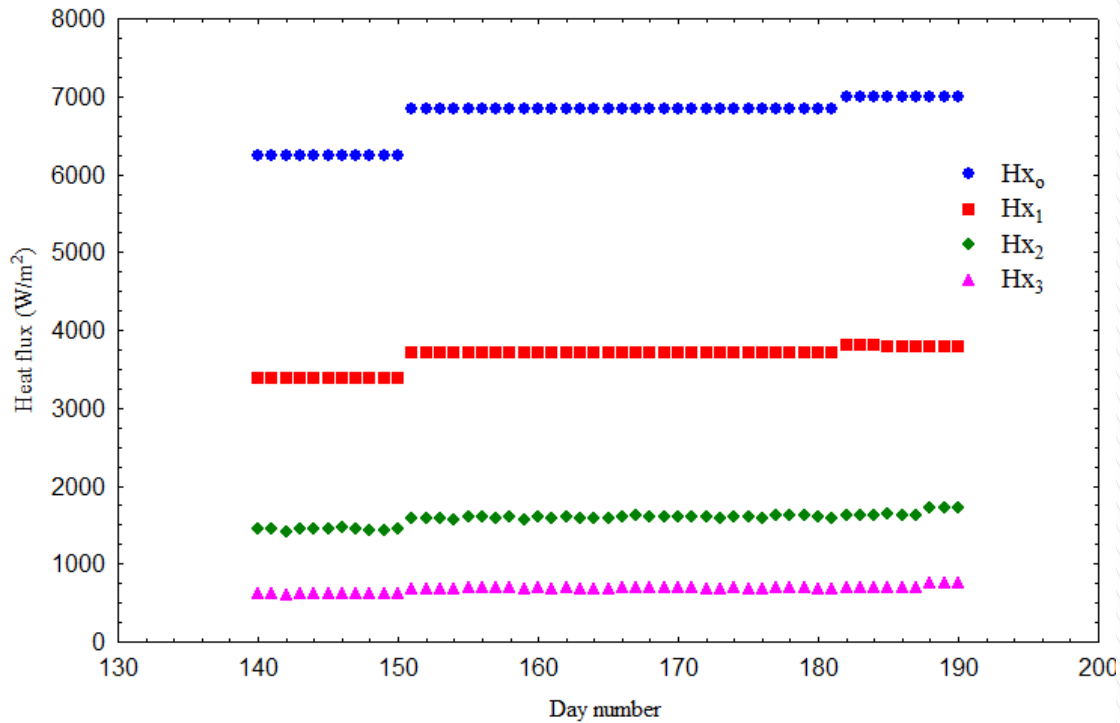

Heat flux to the solar pond as a function of depth (x) and day number in the year 2015

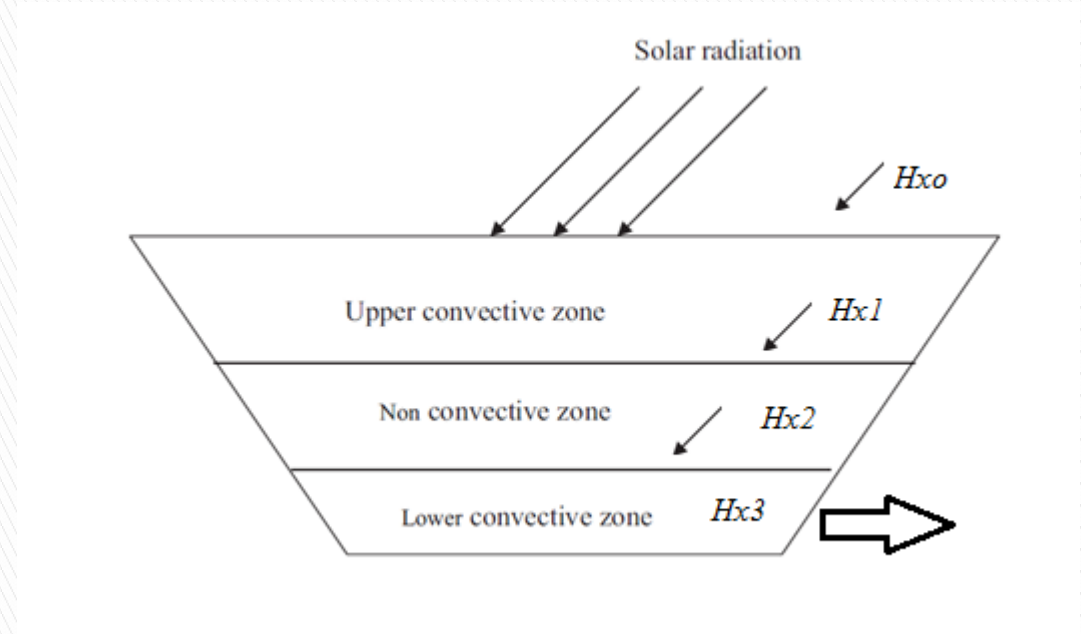

Heat flux to each zone

Solar pond diagram

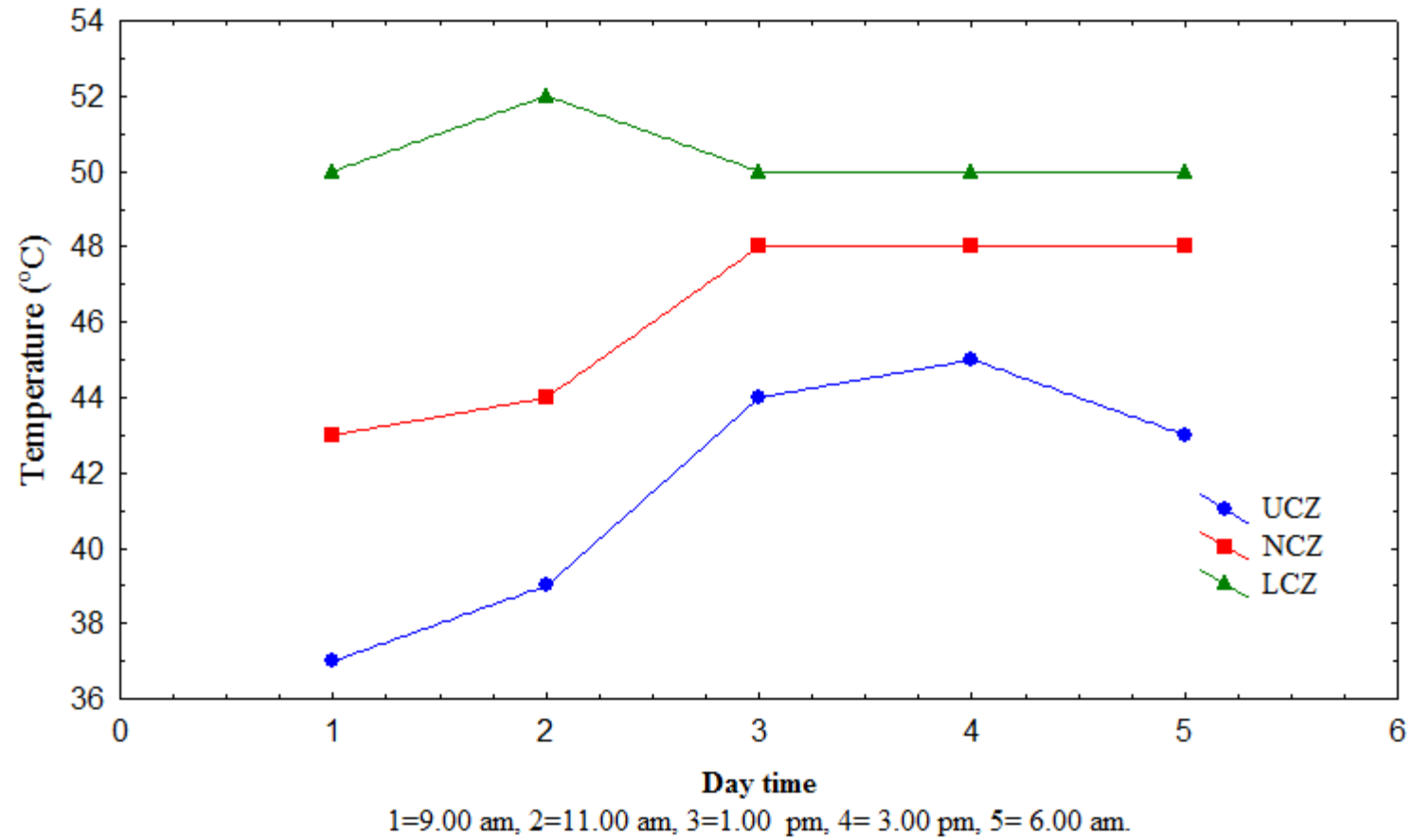

Temperature distribution in layers of solar pond during 10, June, 2015.

Results – Solar Still

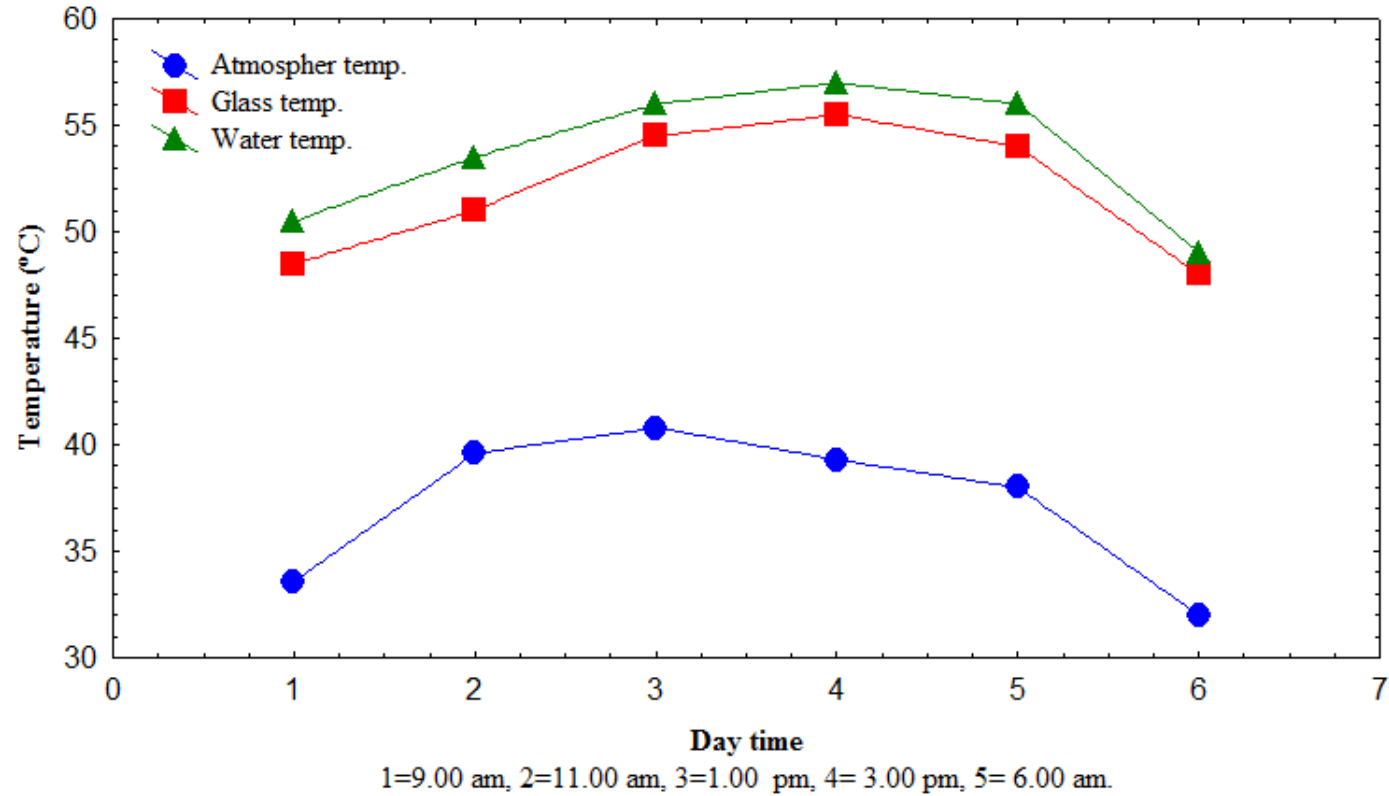

Temprature distribution in solar still in presence of solar pond effect during 15, June, 2015.

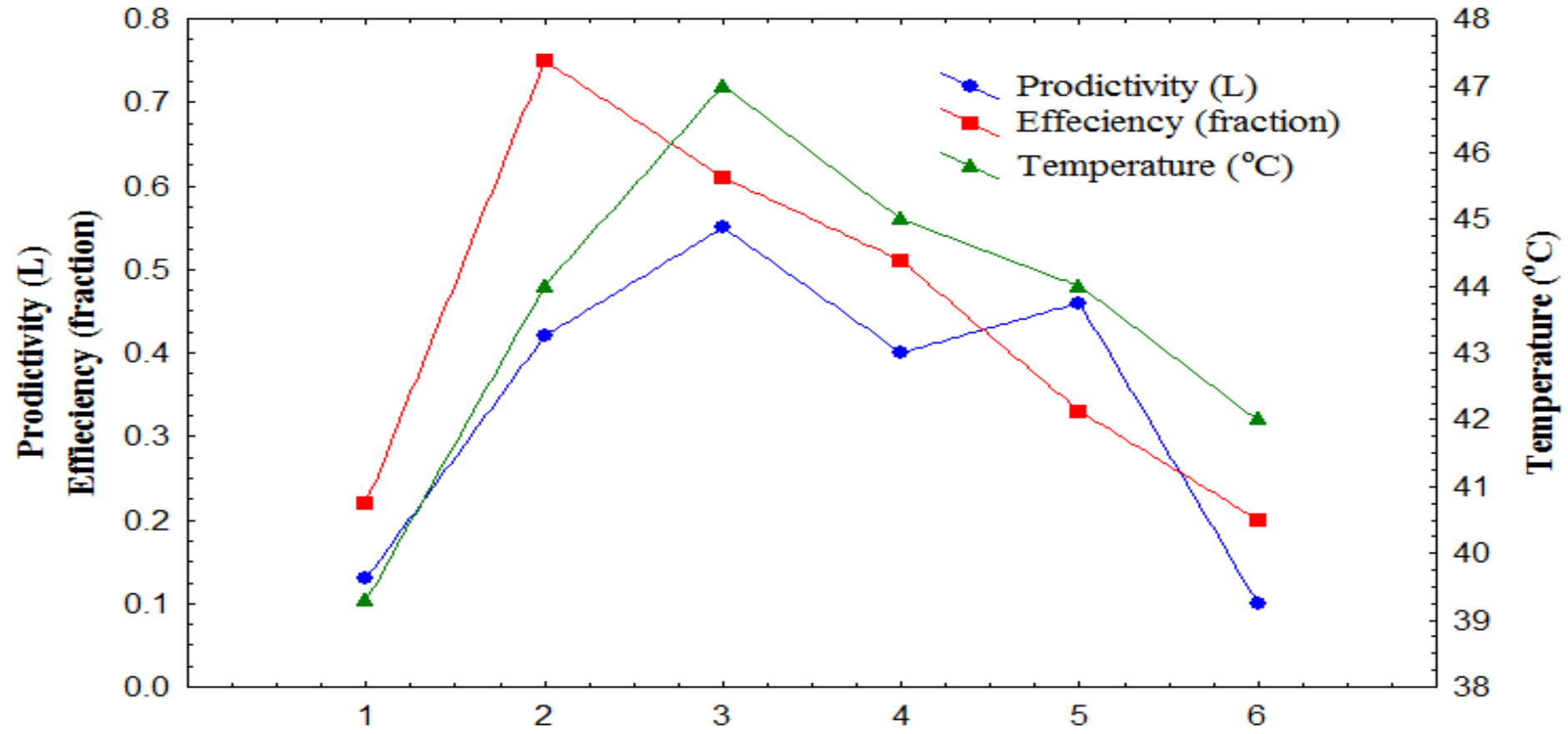

Day time during 20, May, 2015 (Solar Still without cover)
 1=9-10 am, 2=10-12 am, 3=12-1 pm, 4=1-3 pm, 5=3-6 am, 6=6-7 pm

Productivity and efficiency of solar still as a function of time and temperature

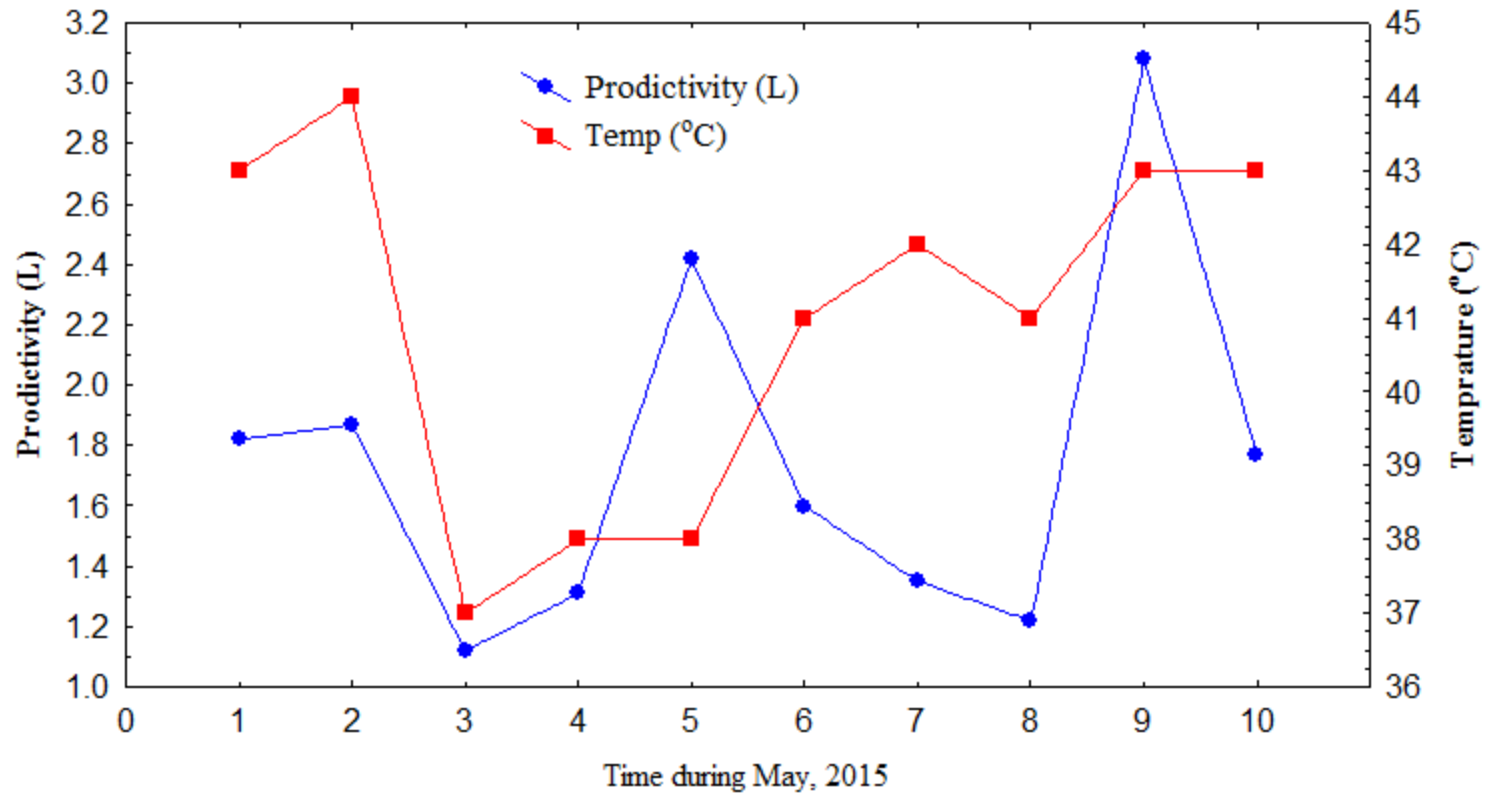

1=20 May, 2=21May, 3=22 May, 4=23May, 5=24May
 6=25May, 7=26May, 8=27 May, 9=29May, 10=29May

Accumilative productivity of distilled water from solar still in absence of solar pond effect during ten days of May, 2015.

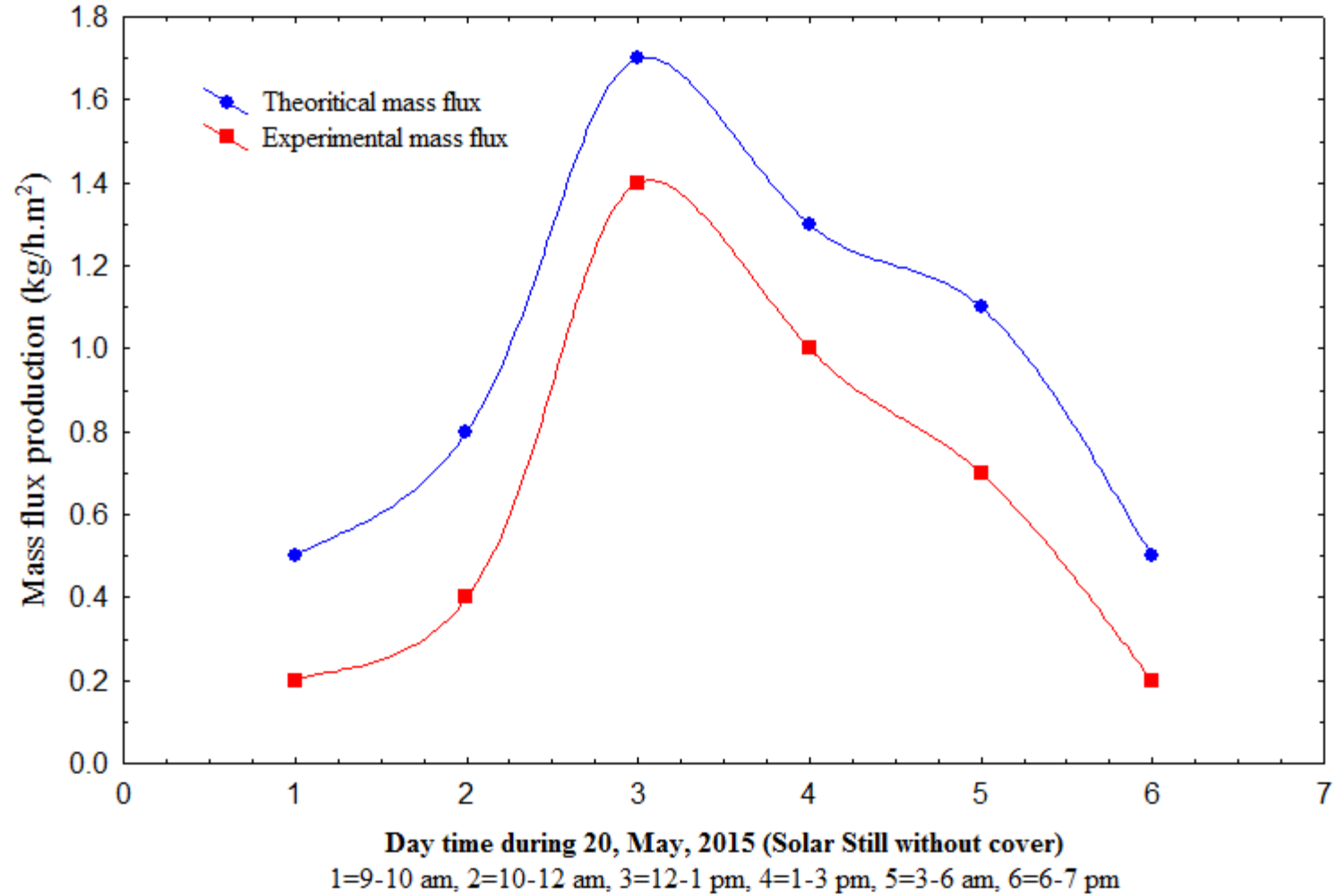

Production of distilled water from solar still without solar pond connection

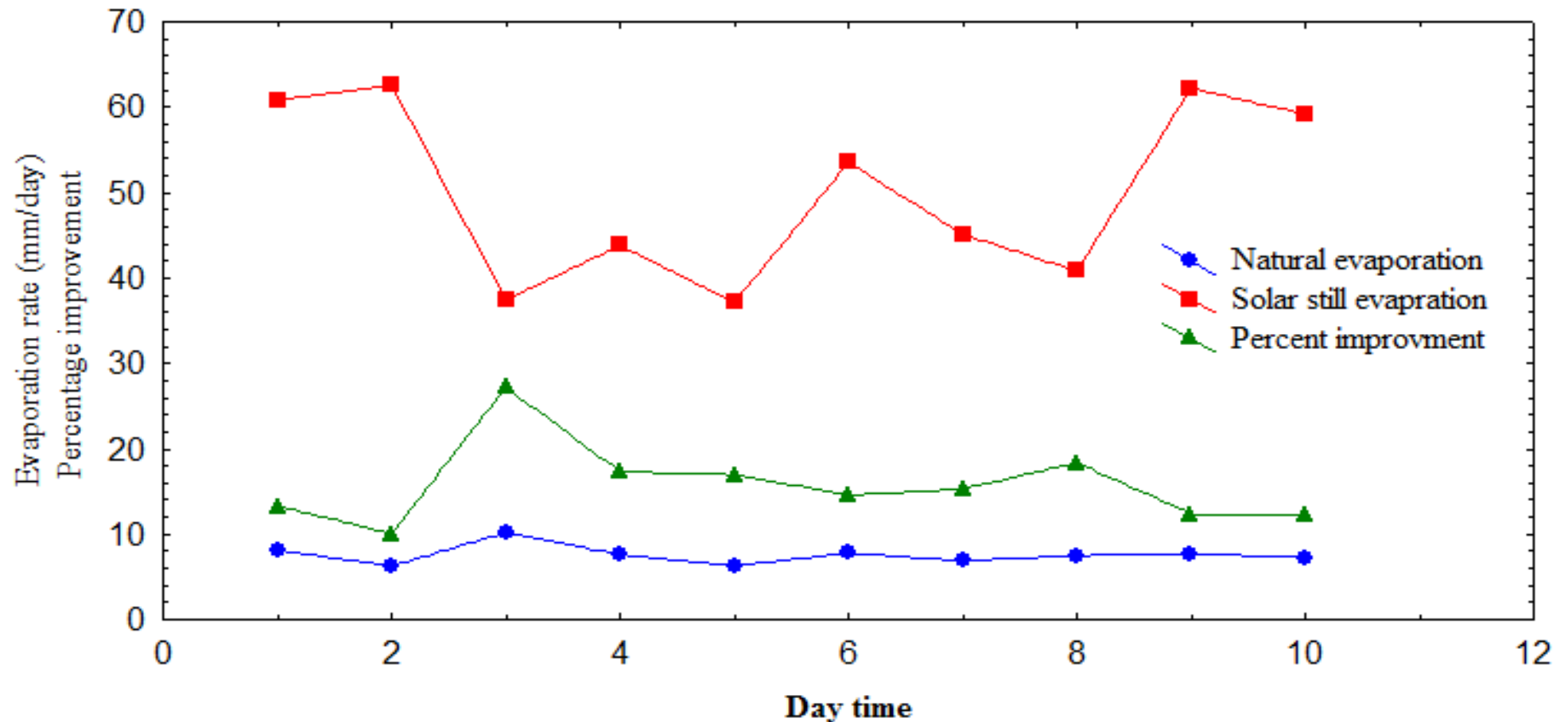

1=21, 2=22, 3=23, 4=24, 5=25, 6=26, 7=27, 8=28, 9=29, 10=30.

Comparison of natural evaporation with solar still evaporation and percent improvement in solar still in absence of solar pond and sun sheet effect during May, 2015.

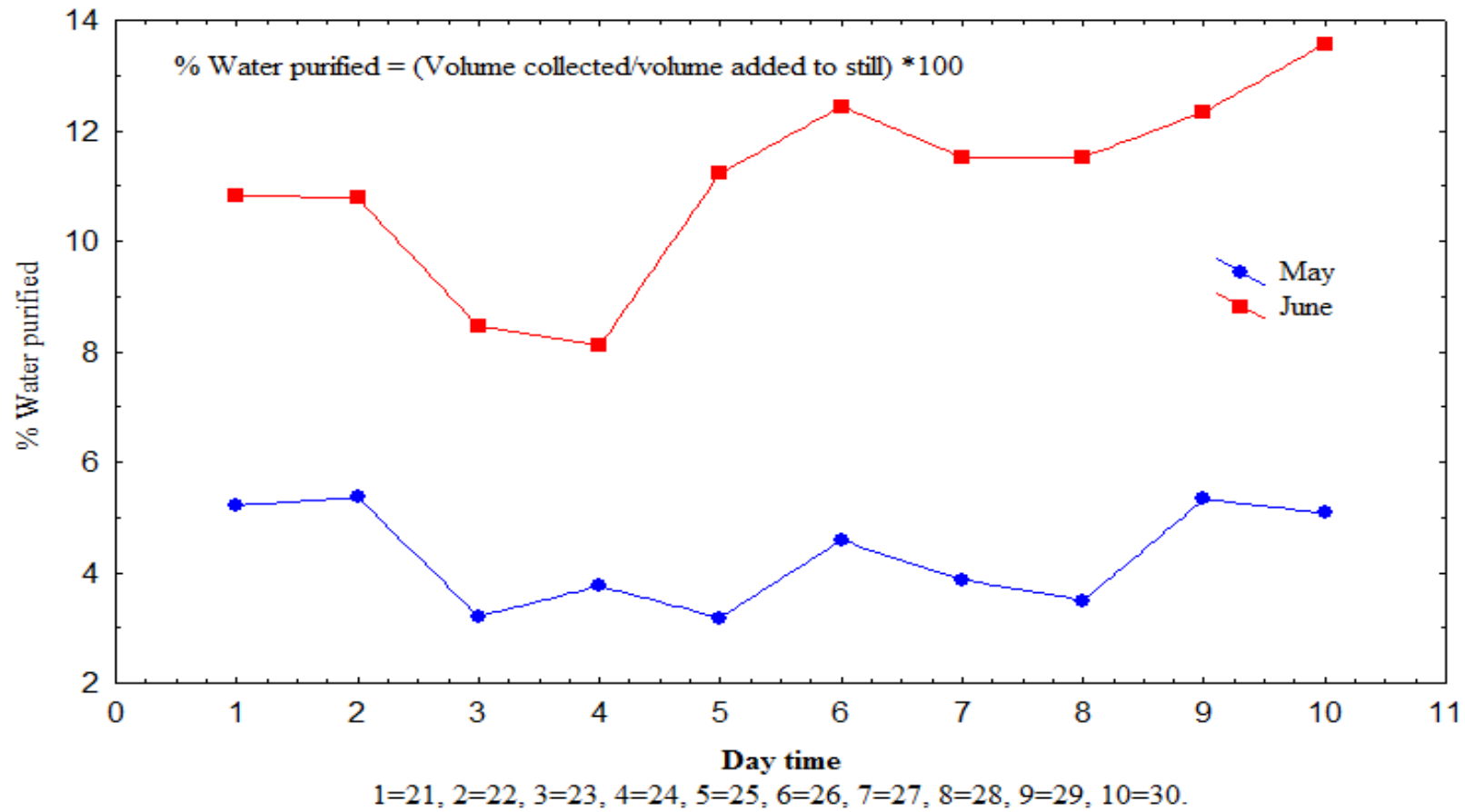

Percent water purification via solar still in absence of solar pond and sun sheet effect during May and June, 2015.

$$\% \text{ water purified} = \frac{\text{volume collected}}{\text{volume added to still}} \times 100$$

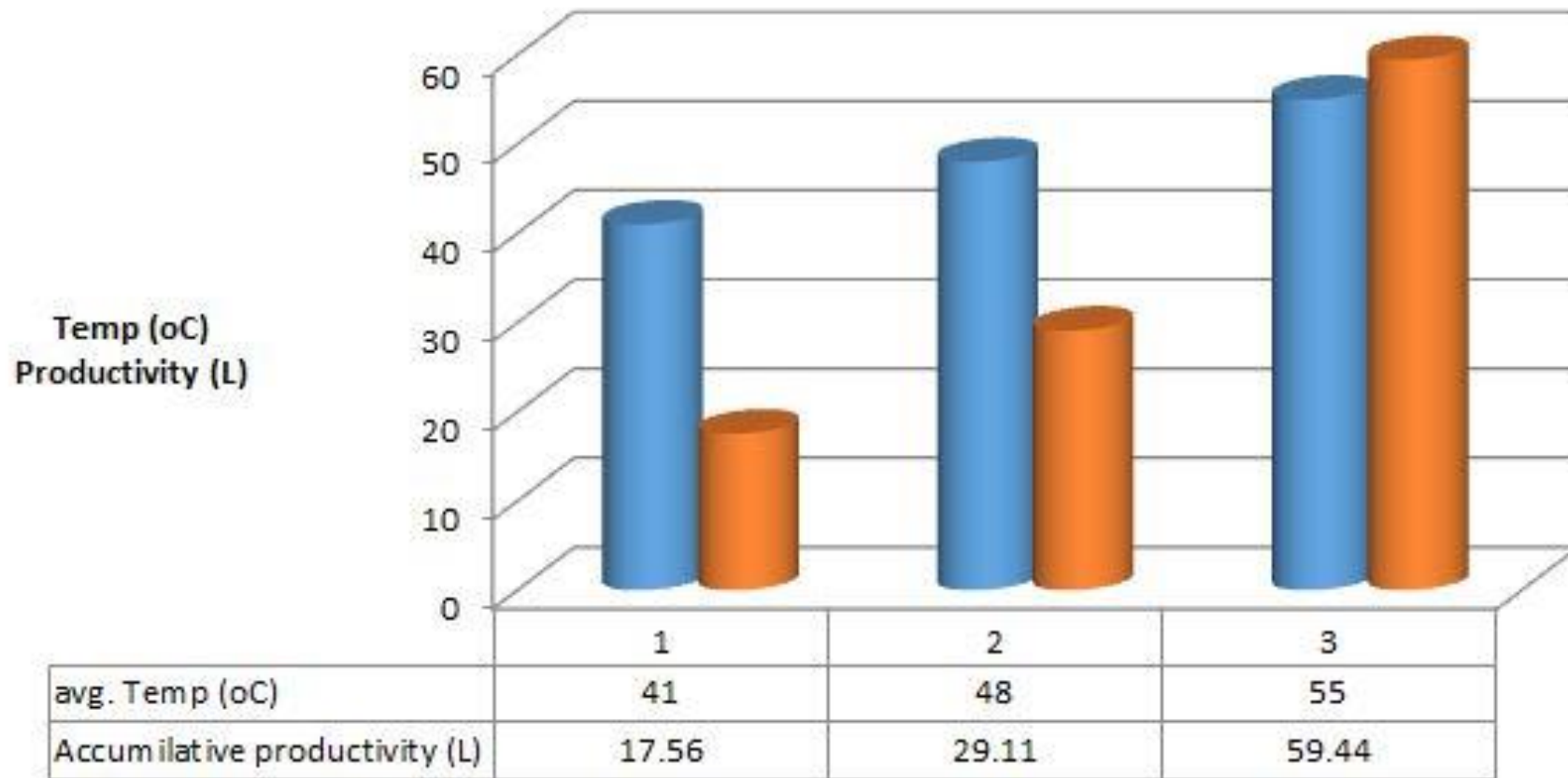

solar still productivity

1= May (Still alone) , 2= June (still+pond) , 3= July (still+pond+sun sheet)

■ avg. Temp (oC) ■ Accumilative productivity (L)

Some recent examples ...



This photo displays a large scale salt gradient solar pond at the University of Texas at El Paso developed by John Walton and Andrew Swift.





MAJOR SALT – GRADIENT SOLAR PONDS (in India)

Location	Area (m ²)	Depth (m)	Main Objectives	Achievements
Bhavnagar (India)	1210	1.2	Operating experience and behaviour of materials	Max. Temp. 80°C in 1972. Worked for two years.
Bhavnagar (India)	1600	2.3	Operating experience and applications for power production.	Getting heated, designed to supply 20 KW. Rankine cycle turbines.
Pondicherry (India)	100	2.0	Experience, material behaviour, monitoring & modeling.	Built in 1980.
Bhuj (India)	6000	3.0	Operating experience, material behaviour and possible applications	Supplying process heat to a dairy

**THANK YOU
FOR
ATTENDING AND LISTENING**

